

e*thirteencomponents XOX INSTRUCTIONS

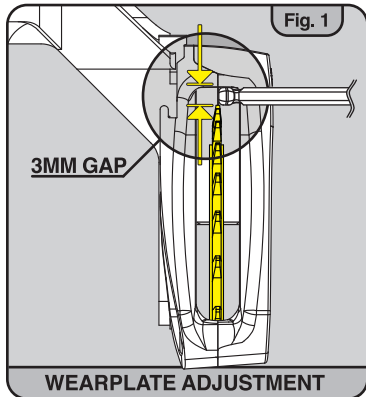

FOR MORE INFO VISIT: BYTHEHIVE.COM/SUPPORT

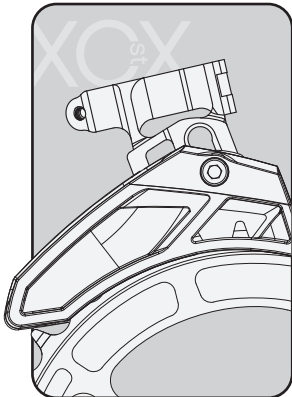

*Do not paint plastics *Do not use "mineral spirit" based chain lubes

REV. B

e*thirteencomponents XOX INSTRUCTIONS



FOR MORE INFO VISIT: BYTHEHIVE.COM/SUPPORT



- 1) Clean clamping surfaces.
- 2) Adjust the upper slider height leaving a 3mm gap between ring and upper slider. Tighten bolt to 0.9Nm(7.9 In-lbs) (Fig. 1).
- 3) Rotate insert until ring aligns with the center seam of the upper slider. Tighten clamp bolt to 1.0Nm(8.8 In-lbs) (Fig. 2).

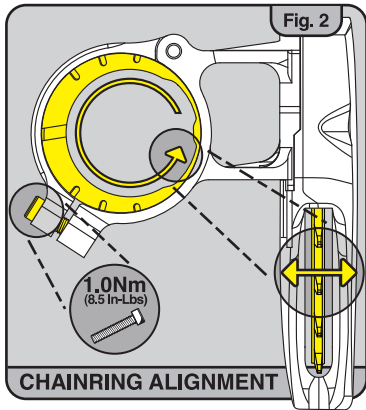

e*thirteencomponents



thehive

405 East D St. Ste.C
Petaluma, CA 94952
1.800.801.9936
bythehive.com