

e*thirteen components XOX E-TYPE INSTRUCTIONS

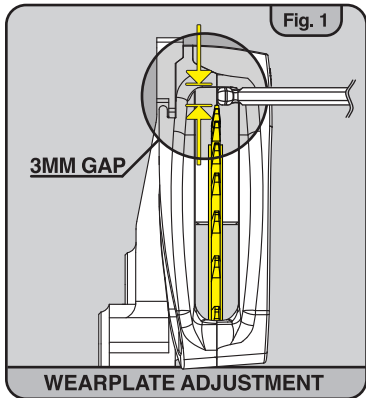

FOR MORE INFO VISIT: BYTHEHIVE.COM/SUPPORT

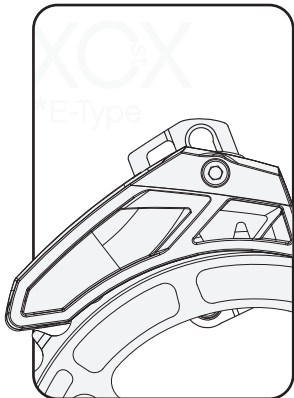

*Do not paint plastics *Do not use "mineral spirit" based chain lubes

REV. B

e*thirteencomponents XOX E-TYPE INSTRUCTIONS



FOR MORE INFO VISIT: BYTHEHIVE.COM/SUPPORT



- 1) Adjust the upper slider height leaving a 3mm gap between ring and upper slider. Tighten bolt to 0.9Nm(7.9 In-lbs) (Fig. 1).
- 2) Add or remove spacers until ring aligns with the center seam of the upper slider. Tighten bolt to 6.0Nm(53 In-lbs) (Fig. 2).
- 3) Use short bolts for no spacer(x0) set up. Use long bolts for set up requiring 1+ spacers.

e*thirteencomponents



405 East D St. Ste.C
Petaluma, CA 94952
1.800.801.9936
bythehive.com

