

**e\*thirteen**components  
Crown chainwheel spacer instructions

STEP 1: spacer washer installation

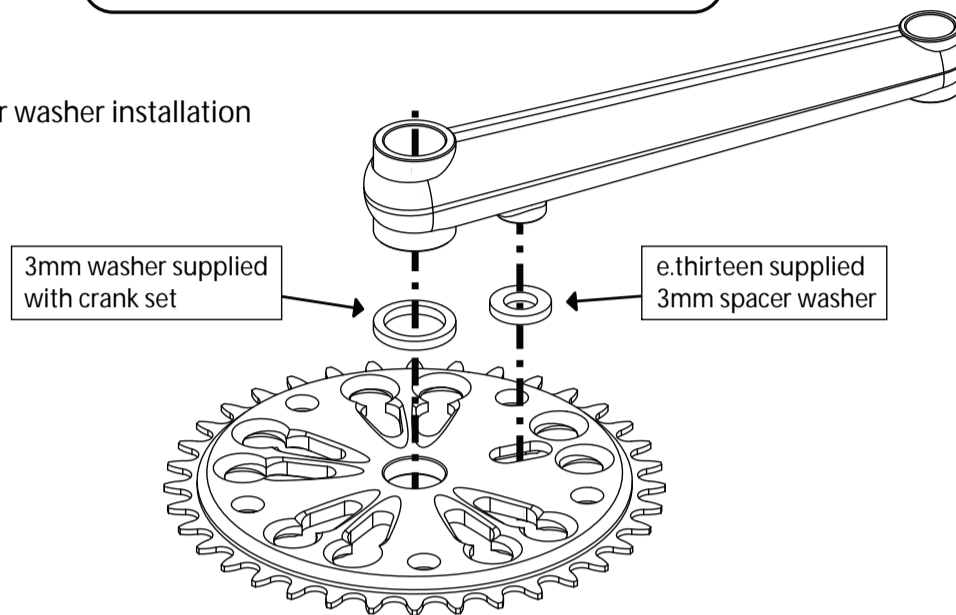

STEP 2: supercharger bashguard installation (not included with crown ring)

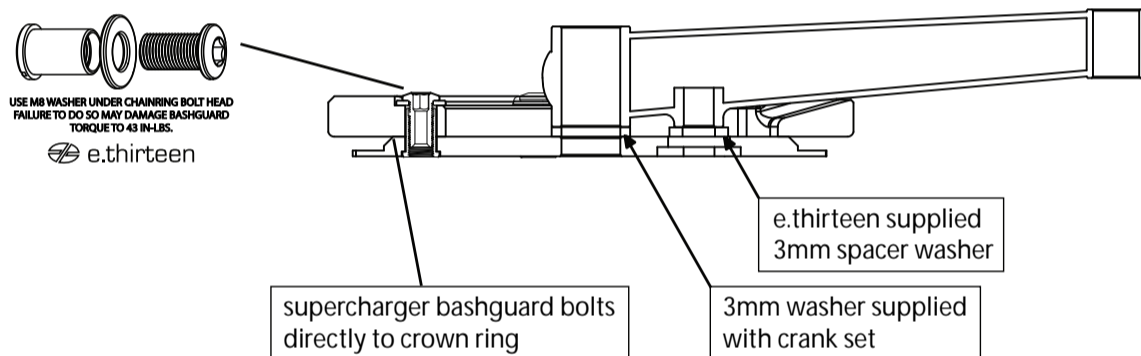

**e.thirteen** crown chainwheel spacer and bashguard installation instructions

- 1) spacer washer and crank installation
  - a) Remove stock spider from crank arm
  - b) Replace spider with Crown Chainwheel, taking care to space out chainwheel so that it clears frame parts and aligns correctly with chainguide if being used. Often this will require a 3mm spacer (included with your 3-piece crankset) behind the chainwheel.
  - c) If you are using a bashguard with your Crown Chainwheel, you may need to space out your crank arm as shown in the illustration above. Use the e.thirteen supplied 3mm spacer washer to space out the drive bolt on your crankarm, along with one 3mm spacer washer that is supplied with your 3-piece crankset. (SEE ILLUSTRATION ABOVE) Using the spacer washer will give the same crank spacing as a stock spider.
- 2) Supercharger bashguard installation
  - a) bolt supercharger bashguard directly to crown ring
  - b) Use M8 washer under the head of each chaining bolt to prevent bashguard damage
  - c) Torque chaining bolts to 43 in-lbs. Do not use threadlocker as it may damage your bashguard

**e\*thirteen**components



405 East D St. Ste.C  
Petaluma, CA 94952  
1.800.801.9936